

GN 177

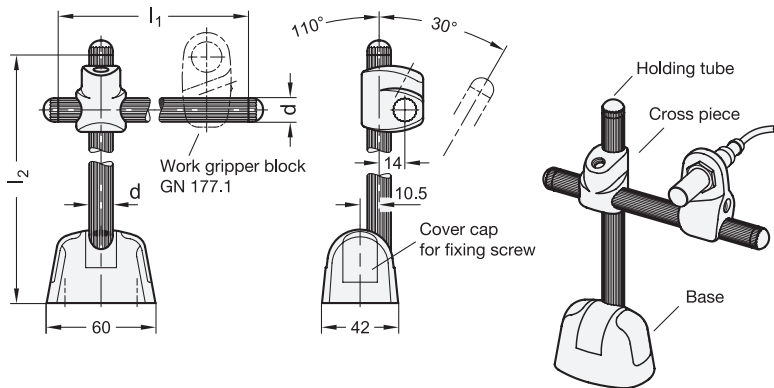

5 Type

- A For sensor mounting
- B For sensor mounting
- C With bore for countersunk screw M6
- D For reflector mounting
- E For reflector mounting

GN 177.1 (Work gripper blocks)

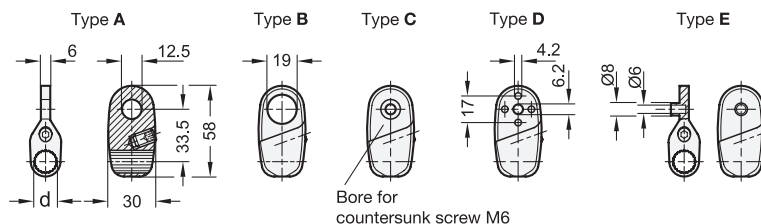

d	l ₁	l ₂				
13	100	116	166	216	266	316
13	150	116	166	216	266	316
13	200	116	166	216	266	316
13	250	116	166	216	266	316
13	300	116	166	216	266	316

Specification

- Work gripper block GN 177.1
Plastic (Polyamide PA)
Black, matte finish
- Base
Plastic (Polyamide PA)
Glass fiber reinforced, black, matte finish
- Color of the cover cap (shiny finish):
 - DSW Black, RAL 9005
 - DOR Orange, RAL 2004
 - DGR Gray, RAL 7035
 - DGB Yellow, RAL 1021
 - DBL Blue, RAL 5024
 - DRT Red, RAL 3000
- Cross piece
Plastic (Polyamide PA)
Glass fiber reinforce, black, matte finish
- Retaining tube
 - Aluminum, plain
 - Cover caps
Plastic (Polyamide PA), black, matte finish
- RoHS

Information

With the universal work holding and positioning fixture GN 177, the work gripper block GN 177.1 can be turned rapidly and safely into the desired position. The adjustable retaining tube fixed in the base has eleven indexing positions.

With only one clamping screw (hexagon socket) each, base, cross piece and the work gripper block GN 177.1 can be fixed on the retaining tubes in the required position.

The serrated profile on the retaining tube prevents any unwanted movement independent of the tightening torque of the clamping screw.

How to order	1	d ₁
	2	l ₁
	3	l ₂
	4	Color of the cover cap

How to order (Work gripper block)	1	d
	5	Type