

Assembly / profile machining

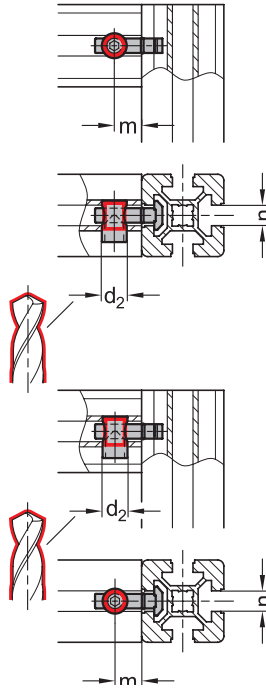

2 Type

A Asymmetrical mounting stud

3 Coding

P Parallel T-nut
R Right-angle T-nut

1

5

n	Bundle Pieces	b	d ₁	d ₂	l ₁ ≈	l ₂ ≈	l ₃	m	A/F	Tightening torque in Nm
8	4	8	6,8	11	33	14,2	20	18	4	12
10	4	10	9,8	17	45,5	18,4	28	22,5	6	25

Specification

- Steel, zinc plated, blue passivated
- RoHS

4

Information

Quick release connectors GN 25b fasten aluminum profiles together at right angles. Only one profile has to be machined.

The connection can be freely positioned and slid along the slot. The internal hex used for clamping is situated for especially easy access.

If panels are used, they must be suitably pocketed, depending on the type, coding and installation orientation.

Quick release connectors are supplied in bundles. The table shows the quantity included in each bundle.

see also...

- Aluminum Profiles GN 10b (Profile Type Light) → Page QVX
- Aluminum Profiles GN 10b (Profile Type Heavy) → Page QVX

How to order

GN 25b-10-A-P-SZ-4

1	n
2	Type
3	Coding
4	Material / Finish
5	Bundle



Assembly Instructions / Profile Machining

Type S

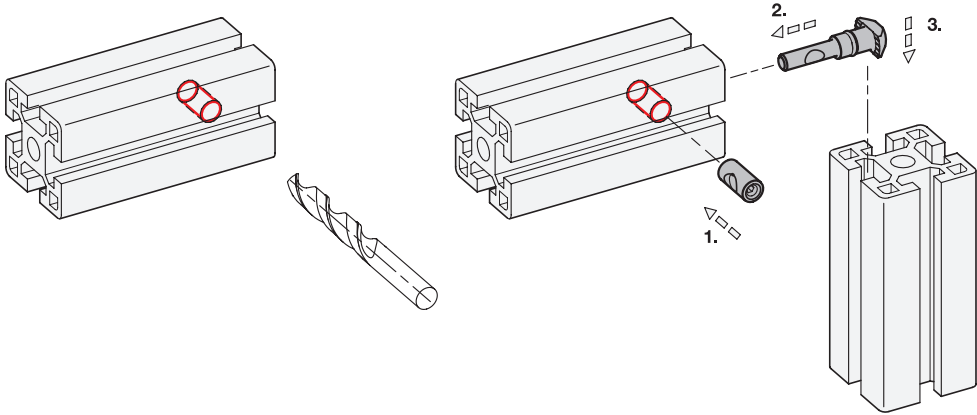

Type A

