

2 Type

A Output on one side

1 3 4

m_1	d_1 j6	Gear ratio i						b_1	b_2	b_3 JS9	d_2 H7	d_3	d_4	d_5	h	l_1	l_2	l_3	l_4	t_1	t_2	t_3	t_4	
20	12	13	15	18	23	30	40	65	35	4	4	12	30	20	27,4	1,5	60	16	12	3	2	13,8	1,6	18,3

Specification

- Housing
 - Aluminum
 - Sealed to prevent dust entry
 - Anodized, natural color
- Worm screw, steel
- Worm wheel, brass
- Ball bearing
 - Steel
 - Sealed (sealing disks 2RS)
- Temperature range: -20 °C to +60 °C
- Keyway P9 DIN 6885 Page 1 → Page 2078
- ISO Fundamental Tolerances → Page 2151
- RoHS

5

Information

Worm gear reducers GN 3975 can transmit high torque despite their very compact dimensions. They can readily be used for a multitude of applications, such as incline adjustments or to change the direction of shaft rotation.

The numerous fastening holes allow for simple mounting in any orientation or position. The parallel keys can take any angular positions.

Depending on the gear ratio, there may be no static self-braking between the worm screw and worm wheel, meaning that the worm wheel can be turned out of a resting state by a torque coming from the output end.

see also...

- Bevel Gear Boxes GN 3971 → Page 2

How to order

1	m_1
2	Type
3	d_1
4	Gear ratio i
5	Finish

GN 3975-20-A-12-23-AN

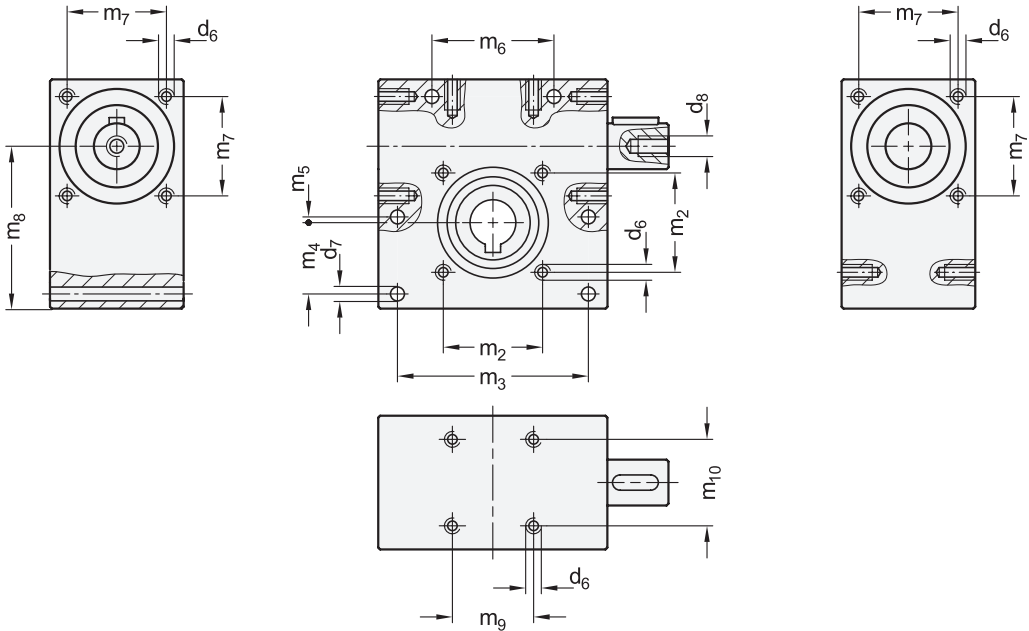

m_1	d_6^*	d_7	d_8^*	m_2	m_3	m_4	m_5	m_6	m_7	m_8	m_9	m_{10}
20	M 4	4,2	M 5	26	50	17,5	1,5	31	26	42,5	22,5	26

* Usable thread depth: min. $1.6 \times d_6 / d_8$

Mechanical Features

Circumferential backlash at the drive shaft	$1^\circ \pm 0.5^\circ$
Shaft direction of rotation	Any
Worm wheel set design	Left-hand
Life expectancy (guideline)	1,000 hours under full load at a rotational speed of 500 rpm, assuming the gear box is operating for 20% of every 5 minutes (1 minute of operation + 4 minutes break) at an ambient temperature of 20 °C
Maintenance	Permanent lubrication with grease, maintenance-free

m_1	Gear ratio	Max. input torque in Nm*			Max. output torque in Nm*			Input side		Output side		Efficiency in %	Self-braking static
		at 100 min ⁻¹	at 500 min ⁻¹	at 1000 min ⁻¹	at 100 min ⁻¹	at 500 min ⁻¹	at 1000 min ⁻¹	Max. radial force in N**	Max. axial force in N***	Max. radial force in N**	Max. axial force in N***		
20	13	2,1	1,8	1,5	15	13	11	200	200	500	500	56	-
20	15	1,5	1,3	1	12	10	8	250	250	500	500	52	-
20	18	1,1	0,9	0,7	11	9	7	250	250	500	500	55	-
20	23	0,9	0,7	0,5	10	8	6	250	250	500	500	50	-
20	30	0,6	0,5	0,4	8,5	7	5,5	350	350	500	500	45	-
20	40	0,35	0,31	0,26	5,5	4,8	4	400	400	500	500	39	x
20	65	0,24	0,2	0,16	4,5	3,8	3	500	500	500	500	29	x

* Input side speed ** at axial force = 0 *** at radial force = 0

Assembly Instructions

Do not exert any forces onto the housing or into the bearings during assembly. Use of the threaded holes d_8 in the shaft is recommended. The use of a corresponding coupling is recommended to compensate for manufacturing-related shaft offsets and runout tolerances as well as for damping vibrations and shocks.