

ROSTFREI  
Inox  
Stainless  
Steel

- 3 Type**
- B** Without rest position, without lock nut
  - BK** Without rest position, with lock nut
  - C** With rest position, without lock nut
  - CK** With rest position, with lock nut

b <sub>1</sub>	l <sub>1</sub>	b <sub>2</sub>	d <sub>1</sub> Plunger Bore H8 <small>-0,02 -0,04</small>	d <sub>2</sub>	d <sub>3</sub>	k	l <sub>2</sub>	l <sub>3</sub>	l <sub>4</sub>	l <sub>5</sub>	A/F <sub>1</sub>	A/F <sub>2</sub>	Spring load in N ≈	
													Initial	End
5	5	2,5	7	M 12 x 1,5	23	20	51,3	20	11,3	1	17	2	9	18
6	6	3	8	M 16 x 1,5	28	24	61,5	24	13,5	1,2	22	2	13	23
8	7,5	4	10	M 16 x 1,5	28	24	61,5	24	13,5	1,2	22	2	15	31
9	8,5	4,5	12	M 20 x 1,5	33	28	72,8	30	14,8	1,2	24	2	19	34

**Specification**

- Guide  
Stainless steel AISI 303
- Plunger pin  
Stainless steel AISI 431, hardened
- Knob  
Plastic (Polyamide PA)  
- Black, matte finish  
- Not removable
- Grub screw DIN 916  
Stainless steel AISI 304
- Compression spring  
Stainless steel AISI 301
- Hex nut ISO 8675  
Stainless steel AISI 304
- ISO Fundamental Tolerance → Page XYZ
- Plastic Characteristics → Page XYZ
- Stainless Steel Characteristics → Page XYZ
- RoHS

**Accessory**

- Distance Bushings GN 609.5 → Page XYZ

**Information**

Indexing plungers GN 824 have a plunger pin with square cross-section, a latching surface on one side and a chamfer on the other. When the object to be secured moves towards the chamfer, the plunger pin is pushed back into the guide, allowing grooves and edges to pass over the pin. The latching can be released by pulling the knob.

Type C / CK indexing plungers with rest position are used for applications when the plunger pin is temporarily not to engage. In that case, the knob is retracted and afterwards turned by 90°. A notch keeps the plunger in this position.

When the grub screw is not tightened, the orientation of the bevel can be freely adjusted over a range of 360°. This can be identified by the marking on the indexing plunger guide.

see also...

- List of Indexing Plunger Types → Page XYZ ff.
- Indexing Plungers GN 817 (without Chamfered Pin) → Page XYZ ff.
- Indexing Plungers GN 617 (without Chamfered Pin) → Page XYZ ff.

How to order		1	b <sub>1</sub>
		2	l <sub>1</sub>
GN 824-8-7,5-CK-NI		3	Type
		4	Material

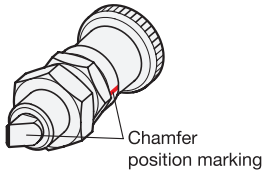

Type B / BK

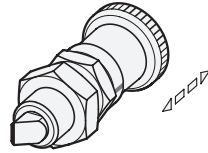

Type C / CK

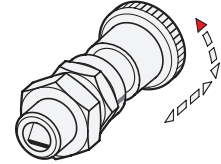

Plunger pin retracted,  
knob turned 90°

## Assembly Instruction

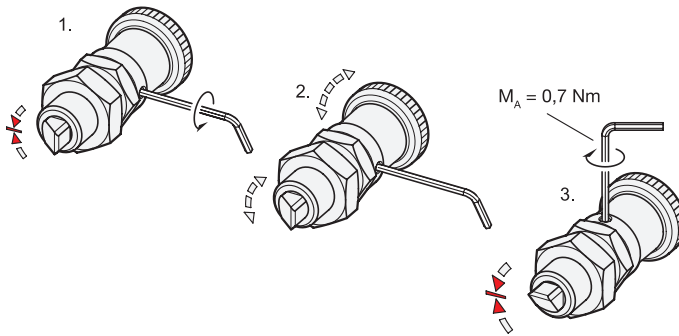

The position of the latching surface can be freely adjusted by 360°.

Installation steps:

1. Loosen the grub screw with a hex key.
2. Turn the knob to move the latching surface in the desired position.
3. Tighten the grub screw with a hex key.

## Application Examples

