

ROSTFREI
Inox
Stainless
Steel

2 Type
AS Body forged

1

Size	Steel	Stainless steel	F _H in N	a	b ₁	b ₂	d ₁	d ₂	d ₃	h ₁ ≈	h ₂ ≈	l ₁
70	70	70	1200	12	64	36	8,5	M 6	4,3	42,5	19,5	86
160	160	160	2800	15	85	46	11	M 6	5,3	59	25	116
360	360	360	5600	25	90	45,5	12	M 8	5,5	75	34,5	122
550	-	-	8000	18	122,5	55	14	M 8	7	82,5	29,5	164,5
1100	-	-	16000	25	133	57	16	M 10	8,5	95	38	182
2100	-	-	25000	35	177	70	20	M 12	8,5	118,5	50	238
3100	-	-	45000	40	216	76	22	M 14	11	137	56	316

Size	Steel	Stainless steel	l ₂ ≈	l ₃	m ₁	m ₂	m ₃	m ₄	s	t	w
70	70	70	79	22	26	13	26	-	6	12	20
160	160	160	107	31	33,5	11,5	36,5	-	7	12	30
360	360	360	114	32	33,5	30	36,5	-	7	15	32
550	-	-	154,5	42	41	15	35	41	6	16	42
1100	-	-	170,5	49	41	15	35	41	8	18	50
2100	-	-	222	61	50	35	50	50	10	22	60
3100	-	-	300	100	54	40	70	70	10	25	100

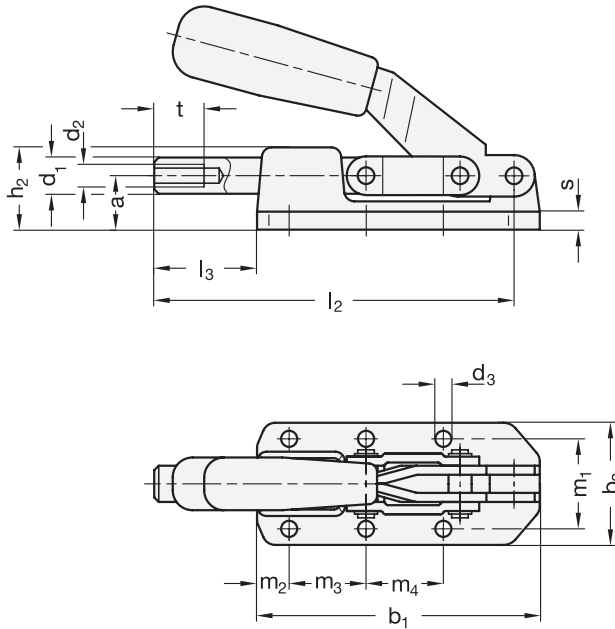

Specification

- Steel —
 - Body manganese phosphated
 - Sheet metal, case-hardened steel C10
 - Zinc plated, blue passivated
 - Plunger. steel St 37
 - Zinc plated, blue passivated
 - Bearing pins (rivets)
 - Case-hardened
 - Zinc plated, blue passivated
- Stainless steel NI
 - Body AISI 304
 - Sheet metal AISI 304
 - Plunger AISI 303
 - Bearing pins (rivets) AISI 304
- All moving parts
- Lubricated with special grease
- Solid designed plastic handle
- Red, oil resistant
- RoHS

Accessory

- Clamping Screws → Page 810 ff.



Information

Push-pull type toggle clamps GN 842 can be used for very high holding capacities thanks to their massive and sturdy body.

On the size 70, the mounting holes are provided with cylindrical counter-sinks for the use of hexagon socket head screws DIN 912-M4.

see also...

- [General Information for Toggle Clamps](#) → Page 698

How to order (Steel)

GN 842-1100-AS

- 1 Size
- 2 Type

How to order (Stainless steel)

GN 842-360-AS-NI

- 1 Size
- 2 Type
- 3 Material

