

Electrical and mechanical characteristics	
Tension feed	Lithium battery CR2477, 3 V
Battery life	3 years
Display	6 digit LCD display, 12 mm high with special character support
Reading scale	-199999; 999999
Number of decimal digits	programmable (see operating instruction)
Unit of measure	mm, inch or degrees (programmable)
Rotation max. speed	300 / 600 / 1000 U/min (programmable, standard 600 U/min)
Precision	10,000 impulses / revolution
Working temperature	0 °C ... 50 °C
Humidity	max. 95 % at 25 °C (without condensation)
Interference protection	acc. to IEC 61326-1

Configurable display options

One advantage of electronic position determination lies in the wide range of display options on the position indicator. The following settings can be configured with the 4 function buttons:

- Selecting incremental or absolute measurement mode
- Changing the unit of dimension (mm, inch or degree)
- Resetting the counter or setting an offset value
- Changing the display value after one turn
- Changing the resolution, i.e. the number of displayed decimal places
- Changing the direction of rotation or counting
- Changing the display orientation (based on the installation orientation)
- Setting the maximum speed of rotation

The installed lithium battery has a life of over 3 years. Time to replace the battery is indicated by a symbol on the display. Battery replacement is easy - simply remove the front cover.

Other important information and instructions can be found in the operating instruction for position indicators GN 9153. This is included with every position indicator and can be downloaded from www.ganternorm.com in the "Service" section.

Description of function

The following components are required to start up the wireless system:

- Electronic position indicator GN 9153
- Control unit GN 9150

Each control unit can be coupled to up to 36 position indicators. A RJ45 network cable is used to connect to the machine control. The following standard bus systems are offered for the control unit:

- Profinet
- Modbus TCP
- Ethernet / IP

The control unit can send the target position value received from the machine control to the position indicators. The indicators then report their current position via radio frequency.

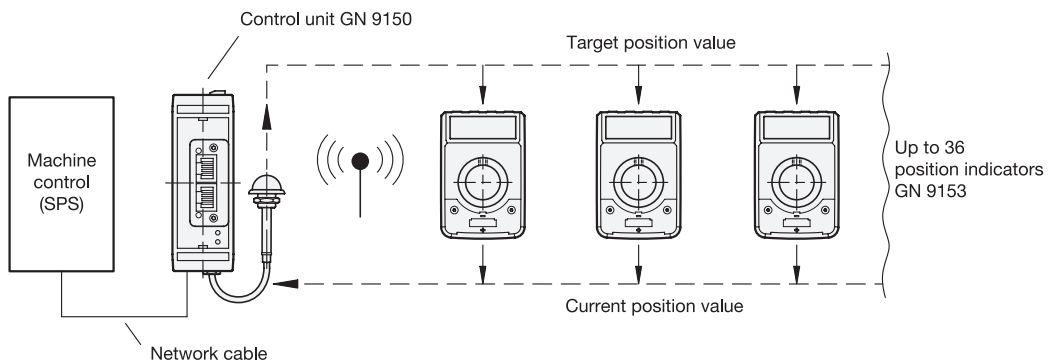

If the target position value and current position value do not match, the LCD display of the position indicator begins to flash. The machine technician must then adjust the position indicator to the correct value. The LCD display shows the difference between the target position value and the current position value and the direction in which it must be turned. It must be turned until a value of 0 appears on the display, meaning zero deviation between the current and target position value.

Example: The current position of the position indicator is 80 mm, the specified target position is 100 mm, and a difference of 20 mm appears on the display of the position indicator. The indicator must be turned in the appropriate direction until the value 0 appears on the display.

The position indicators communicate with the control units via a proprietary ELESA protocol and use the ISM SRD frequency range of 2.4 GHz – 2.48 GHz. The following data is communicated over the radio signal:

- Target position value of the position indicator
- Current position value of the position indicator
- Battery change required

The effective range of the radio communication is up to 30 meters. The antenna of the control unit must be in a clear and ideally high location. It can also be extended, if necessary.

The response time of a position indicator to the control unit via radio communication is 1 second. When using multiple position indicators, these are connected in series; in other words, the maximum number of 36 position indicators results in a response time of 36 seconds. The response time can be shortened if necessary; however, this reduces the battery life.

Installation instructions

Regarding the mounting options and external architecture, electronic position indicators GN 9153 with data transmission via radio frequency are very similar to mechanical position indicators GN 953 (→ Page 396) and can normally be substituted for the latter (see also „Explanations about position indicators“ → Page 394).

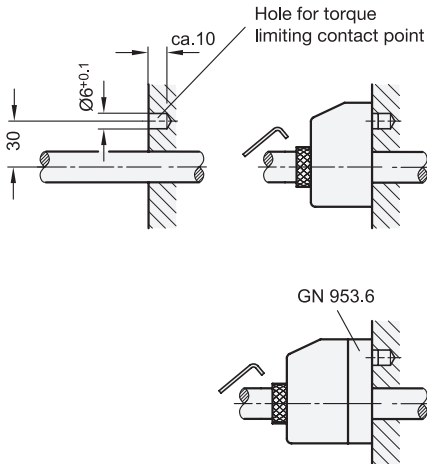

Before installation the position indicator, a locating hole must be made on the machine side for the torque limiting contact point, according to the drawing (see left).

With the **mounting adaptor bushings GN 952.1** (→ Page 412), the hollow shaft (with bore 14 H7) of the position indicator can be adapted to fit the spindle.

If a reduction in the diameter of the hollow shaft is to be made at the same time as mounting a control knob, **control knobs GN 957** (→ Page 413) are available which combine both functions in a single component.

The position indicator is mounted with the torque limiting contact point inserted in the bore hole, to stabilize the housing in place. The hollow shaft is mounted to the spindle and secured with the grub screw.

With **clamping plates GN 953.6** (→ Page 414), spindles can be clamped and secured after adjusting.

Security information

The position indicators and control communicate using a proprietary ELESAs protocol. The control unit can only process the target and current position value of the position indicators and send these to the machine control. The machine control therefore cannot be accessed directly over the wireless network of the control unit. The radio communication is therefore protected against system alterations or third-party access.

Disruptions or interference from other typical wireless networks, such as WiFi, Bluetooth, etc. do not impair the functioning of the system, but they may lengthen the response time of the position indicators to the control unit.

Avoid placing the control unit immediately next to high-powered components, such as motors, converters, etc. If this is not possible, a safe distance of at least 200 mm should be ensured.