

Operating principle

The position indicator is equipped with a hollow shaft that is slid directly onto the spindle and is connected to the spindle by a grub screw. The spindle rotations are transmitted to a counter directly by a gearbox. For torque support, a pin of the housing projects into a hole made on the machine-side, establishing the position relative to the mounting site.

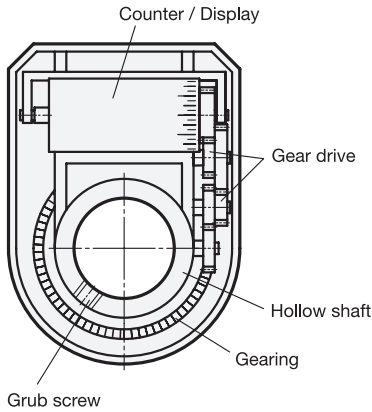

The transmission ratio and counting direction of the counter are determined by the pitch of the adjusting spindle. The indicated value after one turn starting from the 0 position serves as a characteristic value. Decimal places are indicated in red.

Position indicators are also suitable for motor-driven spindles up to a maximum speed.

Operating principle

The electronic position indicators GN 9053 / GN 9054 / GN 9153 are very similar to the mechanical position indicators GN 953 / GN 954 / GN 955 with regard to installation and external dimensions and can normally replace them.

The protection class IP 65 or IP 67 of the housing permits use in wet areas, even in contact with direct streams of water.

The measurement of the spindle rotations takes place directly, electronically and without contact. The required energy is supplied by a lithium battery with a lifespan of 5 or 8 years that can be easily replaced.

The special advantage of the electronic position indicator lies in its programmability. Nearly any desired counting option can be configured directly on the device using the operating buttons.

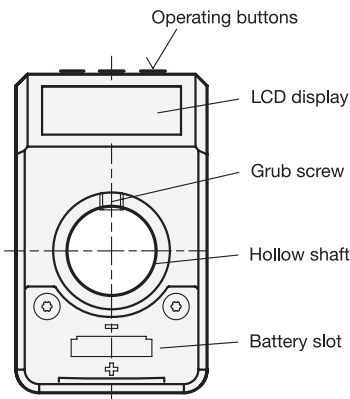

With 3 or 4 operating buttons, it is possible to:

- selecting between incremental or absolute measurement mode
- changing the unit of measure (mm, inch or degree)
- resetting the counter or selecting a predefined offset value
- changing the display after one turn of the shaft,
- determining the resolution, i.e. the number of decimal points displayed
- determining the direction of rotation / direction of counting
- determining the display orientation (as a factor of the installation position), and
- specifying the maximum speed of rotation.