

## Information

The load capacities specified in the table for the double sided shearing resistance (breaking strength) have been calculated or theoretically defined on the basis of DIN 50141.

At the same time, the endangered bolt cross-section S, according to a nearby sketch, was considered in two shear planes before breakage.

The values were arrived at by a series of tests whereby a limited number of levelling feet were subjected for a limited time to a vertical static load to the feet. In general, they do not constitute a warranty of condition.

The user must determine whether the product is suitable for the intended purpose. Environmental factors can influence the specified values.

An appropriate safety factor must be taken into account in the design.

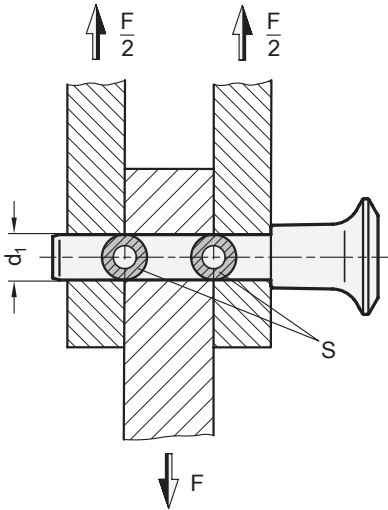

### Ball Lock Pins

Load capacity F in kN ≈ double sided shearing resistance acc. DIN 50141 (breaking strength)

d <sub>1</sub> Pin dia- meter	GN 113.3	GN 113.4	GN 113.5	GN 113.6	GN 113.7	GN 113.8	GN 113.9	GN 113.10	GN 113.11	GN 113.12	GN 113.30
5	14	24	14	24	14	24	14	24	14	24	-
6	21	35	21	35	21	35	21	35	21	35	23
8	38	63	38	63	38	63	38	63	38	63	43
10	60	100	60	100	60	100	60	100	60	100	69
12	87	144	87	144	87	144	87	144	87	144	-
16	155	257	155	257	155	257	155	257	155	257	-
20	244	403	-	-	244	403	244	403	244	403	-
25	386	631	-	-	386	631	386	631	386	631	-

### Lock Pins

Load capacity F in kN ≈ double sided shearing resistance acc. DIN 50141 (breaking strength)

d <sub>1</sub> Pin dia- meter	GN 114.2	GN 114.3	GN 114.6	GN 124.1	GN 124.2	GN 124.3	GN 214.2	GN 214.3	GN 214.6	GN 314
6	14	17	17	22	22	-	14	17	17	-
8	28	35	35	40	40	40	28	35	35	30
10	38	47	47	62	62	62	38	47	47	46
12	61	75	75	90	90	90	61	75	75	74
16	113	138	138	-	-	-	113	138	138	136
20	187	228	228	-	-	-	-	-	-	227

