

WE MAKE  
INNOVATION



 **newstark**<sup>®</sup>  
INNOVATIVE METAL SOLUTIONS

 **BERGER TOOLS LTD**



Accurate, compact and powerful unit.



Accurate unit.



Adjustable speed.



Anti-rotation system.



Product in 3/4 days for the models 1500-3000.



Product in 3 weeks.



Special Product in 40 days.



Product on stock.



Product on stock for the models 400-900.



Inclinabile su 2 assi.  
2 axis slope.  
Neigung von 2-Achsen.



Balance of the die.



Competitive price.



Use compressed air.



Damage reduction of during maintenance.



Direct use under the press.



Easiness of disassembly and maintenance.



Easiness of application and regulation of metal plates on the slide.



Easy maintenance.



Device with low voltage power supply, 24V / 2A.



Presence of fixing points.



Great power of extraction.



Long stroke.



High quality materials.



Horizontal travel guaranteed.



Interchangeability.



Long duration.



Low power consumption.



Lubricate with appropriate oil.



Product designed and manufactured in Italy by Newstark.



Maximum speed: 40 strokes per minute.



Maximum speed: 50 strokes per minute.



Minimum inclination.



Minimum noise.

# PNEUMATIC SCRAP TRANSPORTER



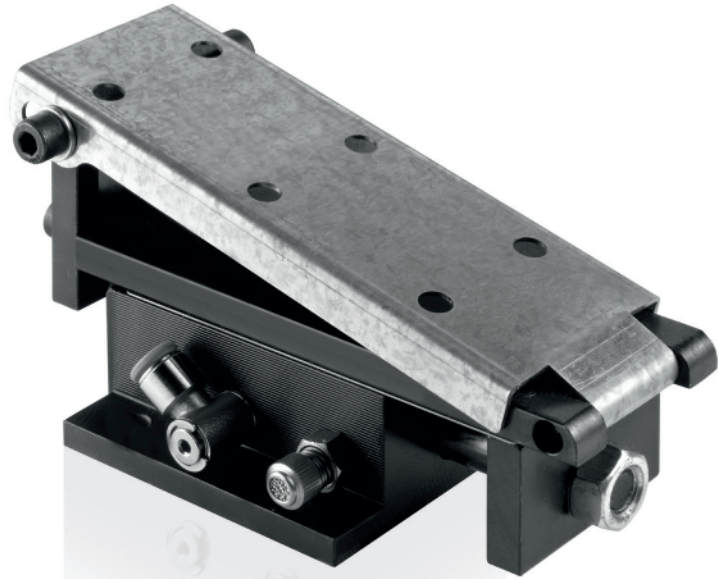

## PNEUMATIC SCRAP TRANSPORTER

Material conveyor mechanism through pneumatic vibrant system, with very small dimensions, applicable even in evacuation uneasy situations. Depending on application requirements, by mean of a slide, different sizes of plates can be applied, this slide is equipped with an adjustment sloping system. This system is activated through compressed air connection previously filtered through a pressure regulator from 2 to 5 bar. Work speed is adjustable through a brass valve directly inserted in the tool.



### STRENGTHS



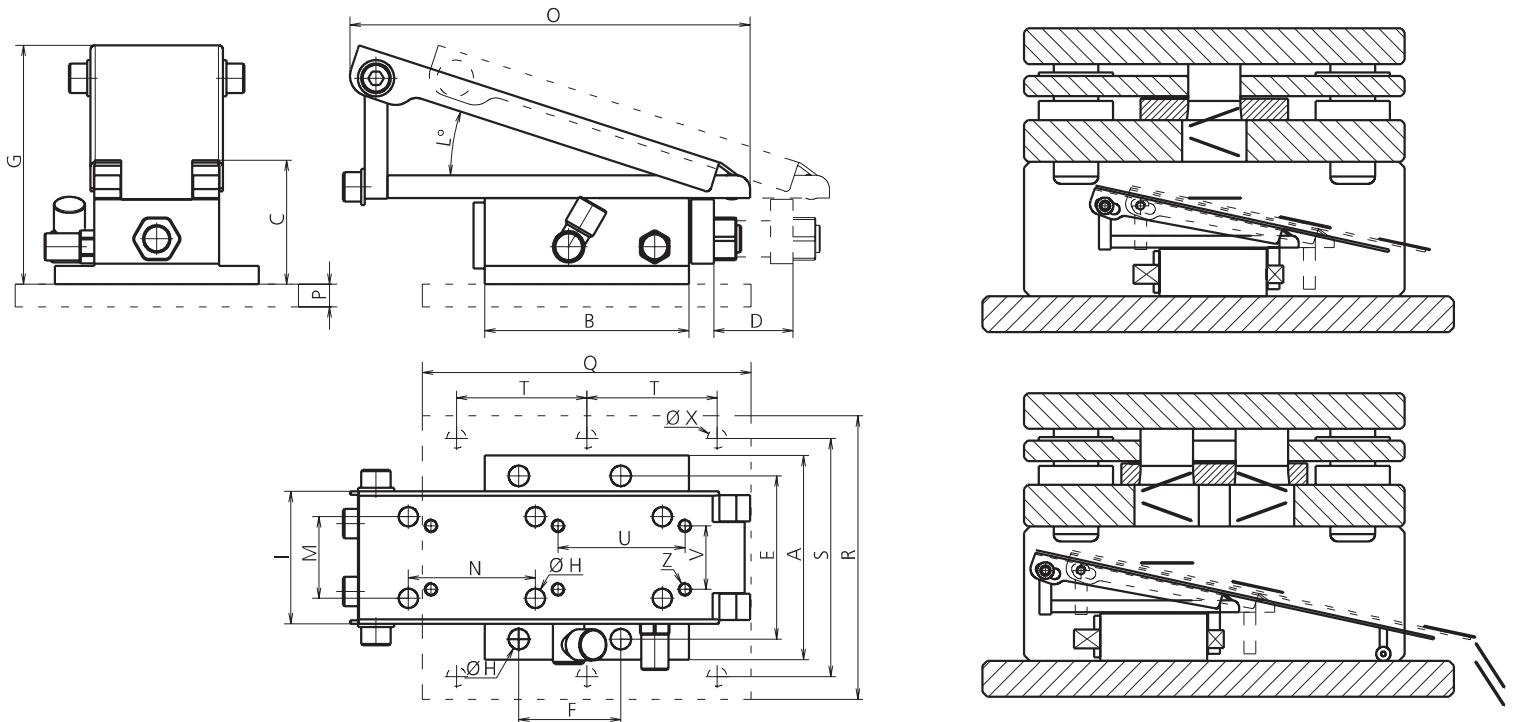

**FEED AIR COMPRESSED**

MODEL	WORKPRESSURE	A	B	C	D	E	F	G MAX	H	I	L MAX-MIN	M	N	O	P	Q	R	S	T	U	V	Z	X	MAX LOAD	
ALO-05	2/5 BAR	90	90	29	20	72	45	83	Ø 8.5	58	18°-7°	36	56	180	/	/	/	/	/	/	/	/	/	/	5 KG
ALO-10	2/5 BAR	90	90	52	30	72	45	105	Ø 9	60	20°-4°	36	56	175	/	/	/	/	/	/	/	/	/	/	10 KG
ALO-25	2/5 BAR	100	106	63	36	82	55	125	Ø 9	70	20°-4°	44	62	190	/	/	/	/	/	/	/	/	/	/	25 KG
ALO-50	2/5 BAR	120	120	72	45	102	96	140	Ø 9	96	20°-4°	56	70	220	/	/	/	/	/	/	/	/	/	/	50 KG
ALO-F10	2/5 BAR	/	/	52	30	/	/	105	/	60	20°-4°	/	/	175	10	145	125	105	57.5	37	25	M6	Ø 8.5	10 KG	
ALO-F50	2/5 BAR	/	/	72	45	/	/	140	/	96	20°-4°	/	/	220	10	208	140	127	63.5	51	70	M8	Ø 9	50 KG	

**IPPLACE A PRESSURE REGULATOR AND LUBRICATOR**

CODE	DESCRIPTION	Q.TY
ALO-9026	KIT REGULATOR+LUBRICATOR	*1 OPTION

**9026.001 # REGULATOR&LUBRICATOR**

**ATTENTION:**  
The compressed air must be clean and free of condensation!

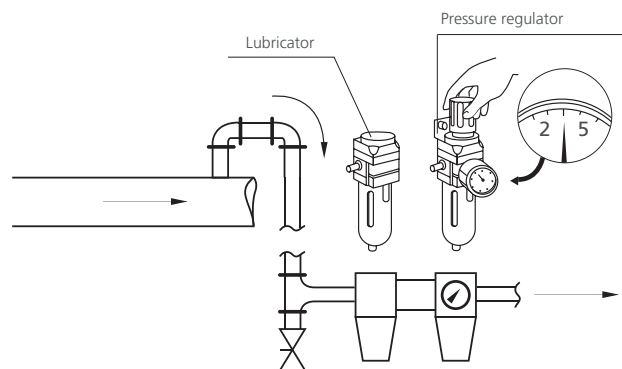

**ORDER EXAMPLE**

MODEL ALO      MAX LOAD 05      OPTION CODE ALO-9026





# ELECTRICAL SCRAP TRANSPORTER

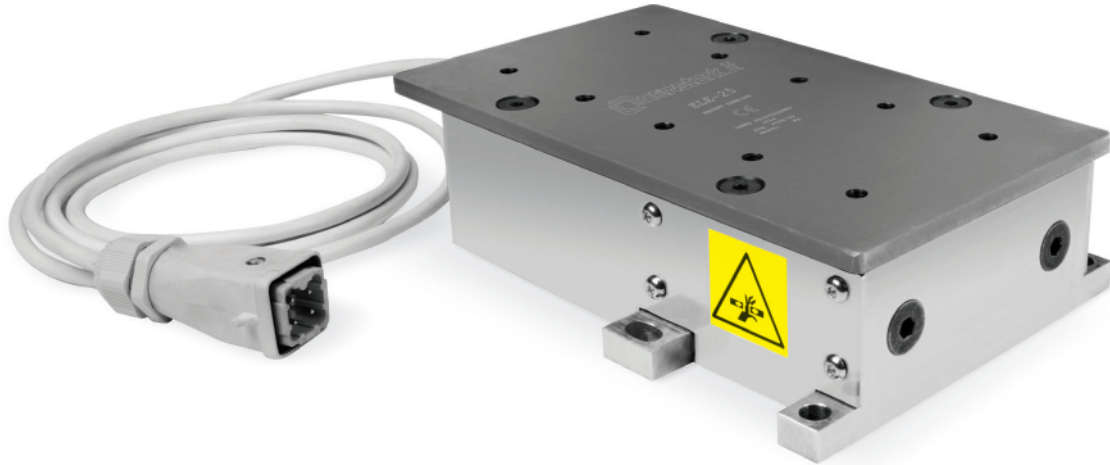

## ELECTRICAL SCRAP TRANSPORTER

Material conveyor mechanism trough electrical vibrant system, with small dimensions, applicable even in evacuation uneasy situations. Depending on application requirements, by mean of a slide, different sizes of plates can be applied. The ejector operation is guaranteed also in horizontal position. The system is activated trough electrical connection 24 V. The power supply control unit, connected to the ejector through a watertight connector, is equipped with a STANDBY warning light, an ON/OFF switch, a potentiometer to adjust the speed and a safety relay that avoids engine damages.



### STRENGTHS





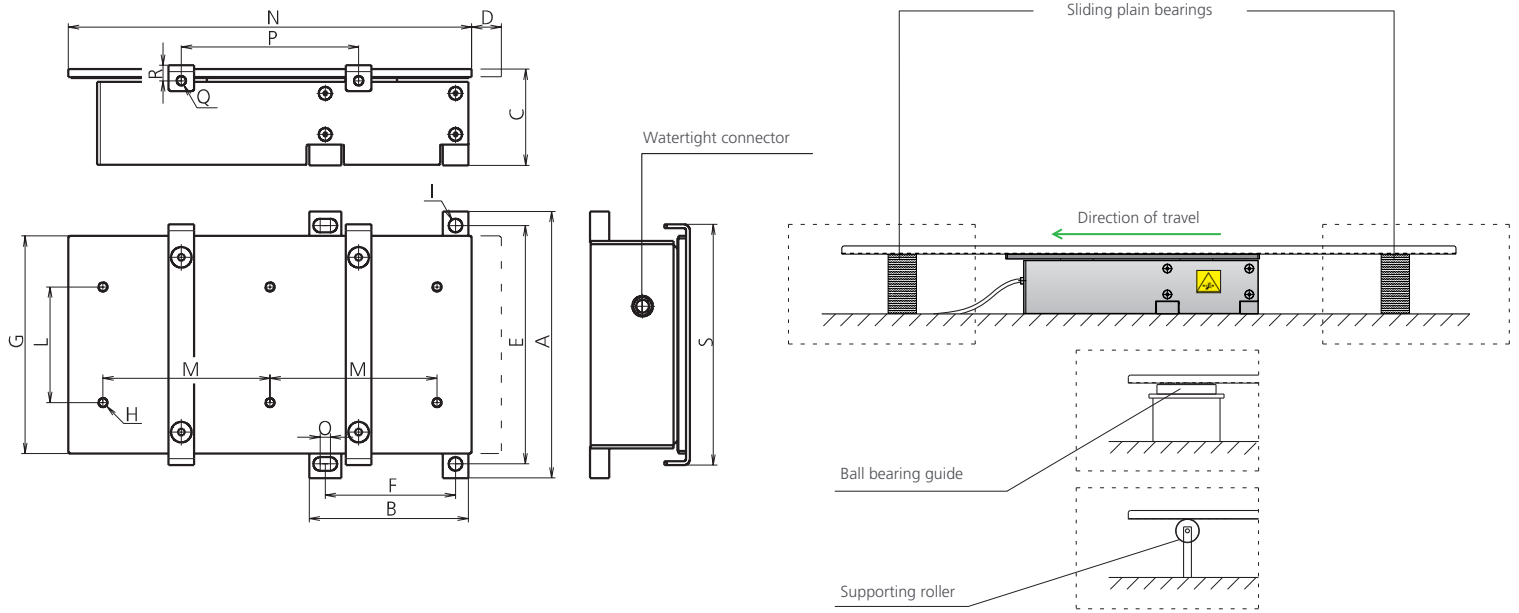

MODEL	A	B	C	D	E	F	G	H	I	L	M	N	O	P	Q	R	S	MAX LOAD
<b>ELE-10</b>	141	86	58	15	127	67,5	118	M8	Ø 8.5	70	75	208	8	100	M8	12	136	10 KG
<b>ELE-25</b>	207.5	124	75	23	185.5	101.5	169.5	M8	Ø 10.5	90	130	314	8	130	M8	12	187.5	25 KG

CODE	DESCRIPTION	Q.TY
<b>ELE8054</b>	POWER SUPPLY CONTROL UNIT/	1*OPTION

DIMENSIONS CONTROL UNIT  
161 x 171 x 82 (h) mm  
THE CONTROL UNIT SUPPORTS AN EJECTOR

**8054.001 POWER SUPPLY CONTROL UNIT**

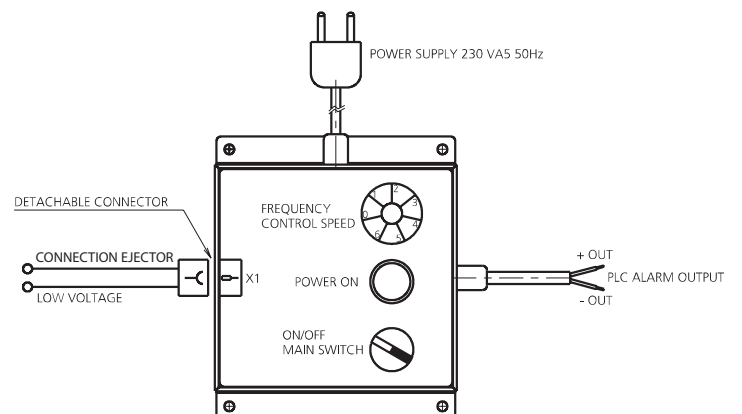
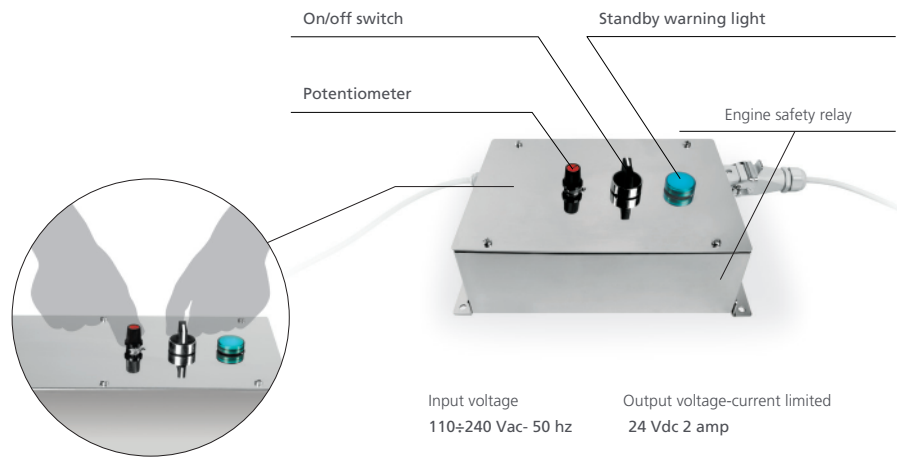

**ORDER EXAMPLE**

MODEL ELE      MAX LOAD 10      OPTION CODE ELE-8054





No horizontal position.



No lubrication is required during work.



Minimum size.



Do not disassemble.



Patent pending.



Use forbidden for persons with pacemakers.



Place a pressure regulator and lubricator.



Product tailored to the customer.



Patented system with integrated nitrogen stripper.



Range weight.



The duration of lifetime of the Newstark products depends on the proper use and maintenance!



Different range of load.



Excellent relation between size and power.



Sliding parts made by self-lubricating materials.



Security Microsensor.



Spare parts on stock.



Special applications achievement.



Slope application.



Standard Bracket.



Uniqueness of the product.



Special applications achievement.



Wide range of models.



Wide range of models.



Variety of applications.



Wide range of dimensions.



To work in combination.



Wide range of models.



CE Label.

# WE MAKE INNOVA- TION



Via Ghebo 24 - 26B  
35017 Piombino Dese  
Padova - Italy

T +39 049 5743140  
F +39 049 9368154  
info@newstark.it



UK Distributor

Unit B1 & B2 Chaucer Business Park  
Watery Lane, Kemsing  
Kent, TN15 6QY

T: +44 (0) 1732 763377  
E: sales@berger-tools.co.uk  
W: www.berger-tools.co.uk

[newstark.it](http://newstark.it)

