

ACP1 AIR CONTROL PACKAGE

NO.	PART	PART NO.
A	FILTER, REGULATOR, LUBRICATOR	FRL-500
B	FOOT PEDAL	250 F310
C	QUICK EXHAUST	SEU 1/4 OR QE4
D	MULTICYL	MC OR XL

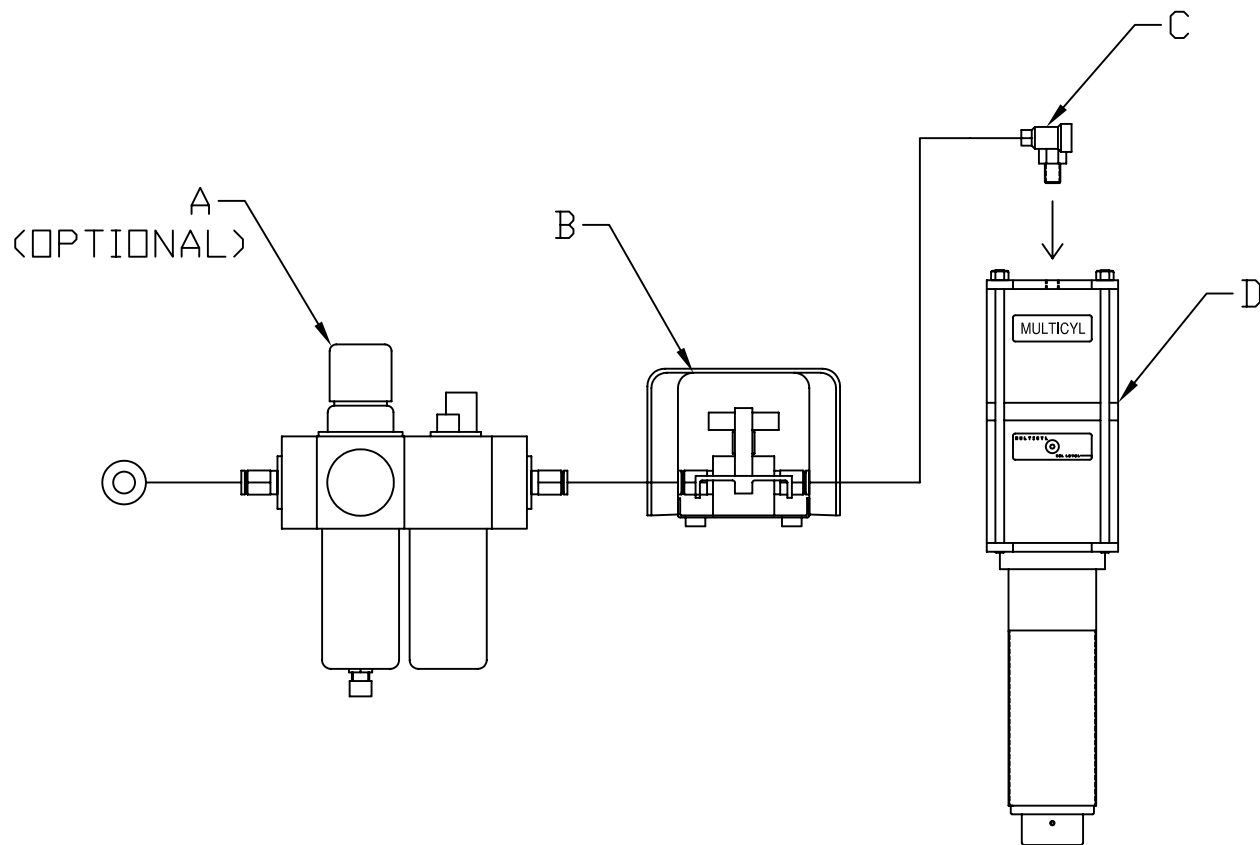

MULTICYL [®] INC.

The SPEED of AIR with the POWER of HYDRAULICS

MULTICYL [®] Inc.
 640 Hardwick Road, Unit 5
 Bolton, Ontario
 Canada L7E 5R1
 (905) 951-0670
 FAX (905) 951-0672

Power Boost Cylinders

Pneumatic Circuit for Power Boost Cylinders

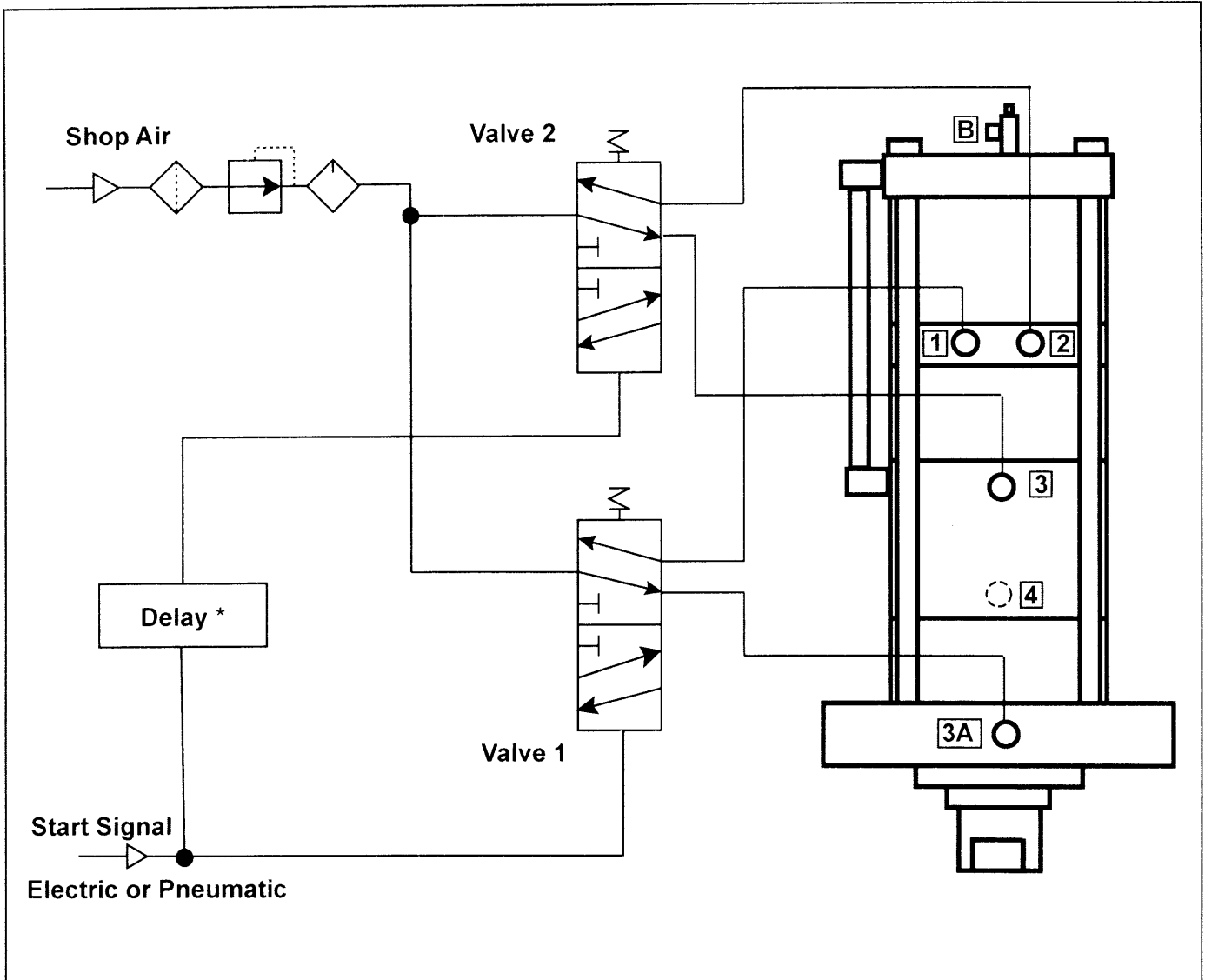

* DELAY: The Power Stroke (High Pressure) can be initiated in many ways, including time delay, pressure build up, pressure decay or position sensing.

SEQUENCE: The sequence of operation must always be low pressure Approach Stroke first, and then the high pressure Power Stroke.

ACP1-DX AIR CONTROL PACKAGE

NO.	PART	PART NO.
A	FILTER, REGULATOR, LUBRICATOR	FRL-500
B	FOOT PEDAL	250 F310
C	QUICK EXHAUST	SEU 1/4 OR QE4
D	MULTICYL	DM OR DX

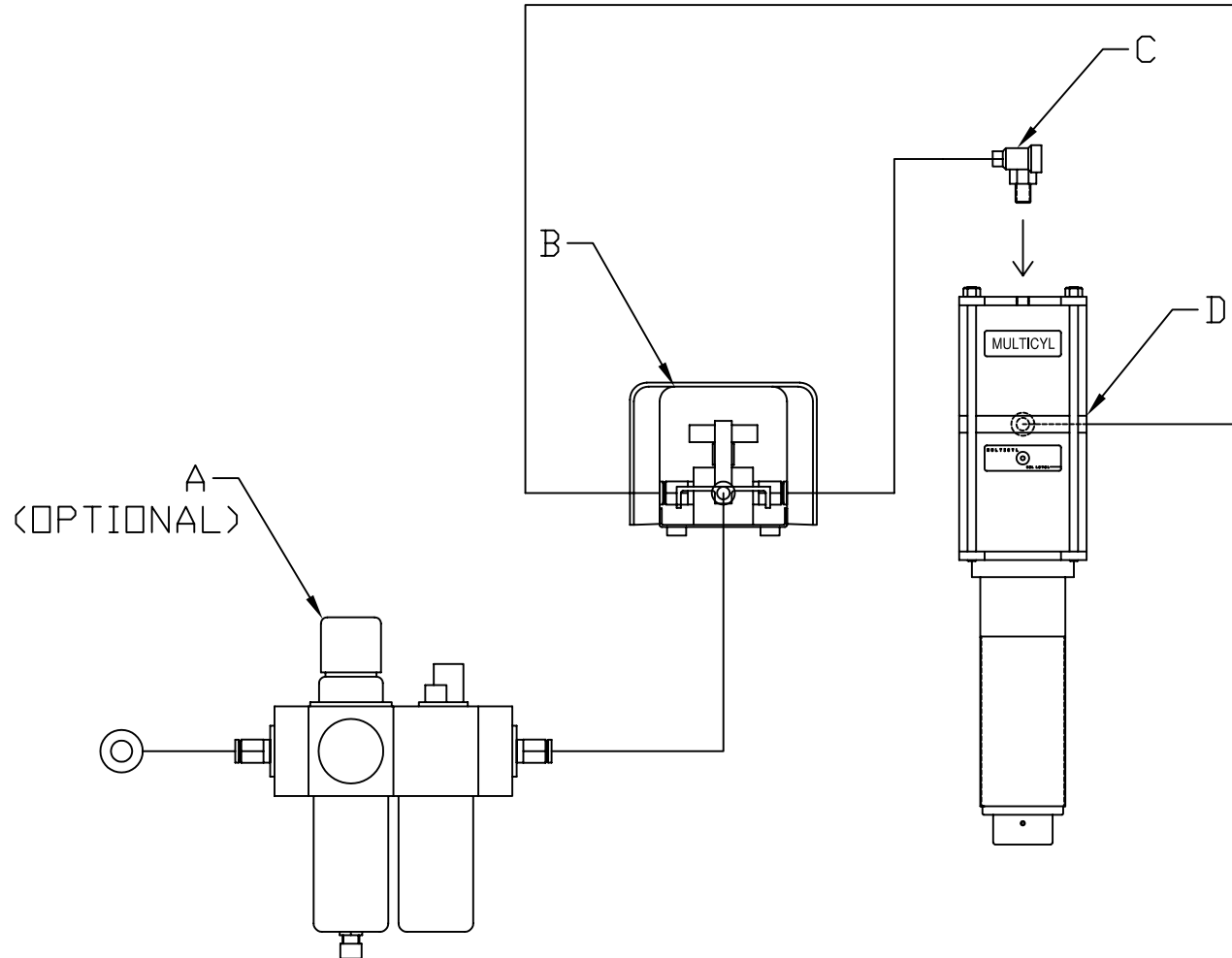

MULTICYL [®] Inc.
 640 Hardwick Road, Unit 5
 Bolton, Ontario
 Canada L7E 5R1
 (905) 951-0670
 FAX (905) 951-0672

ACP1 AIR CONTROL PACKAGE

NO.	PART	PART NO.
A	FILTER, REGULATOR, LUBRICATOR	FRL-500
B	FOOT PEDAL	250 F310
C	QUICK EXHAUST	SEU 1/4 OR QE4
D	MULTICYL	MC OR XL

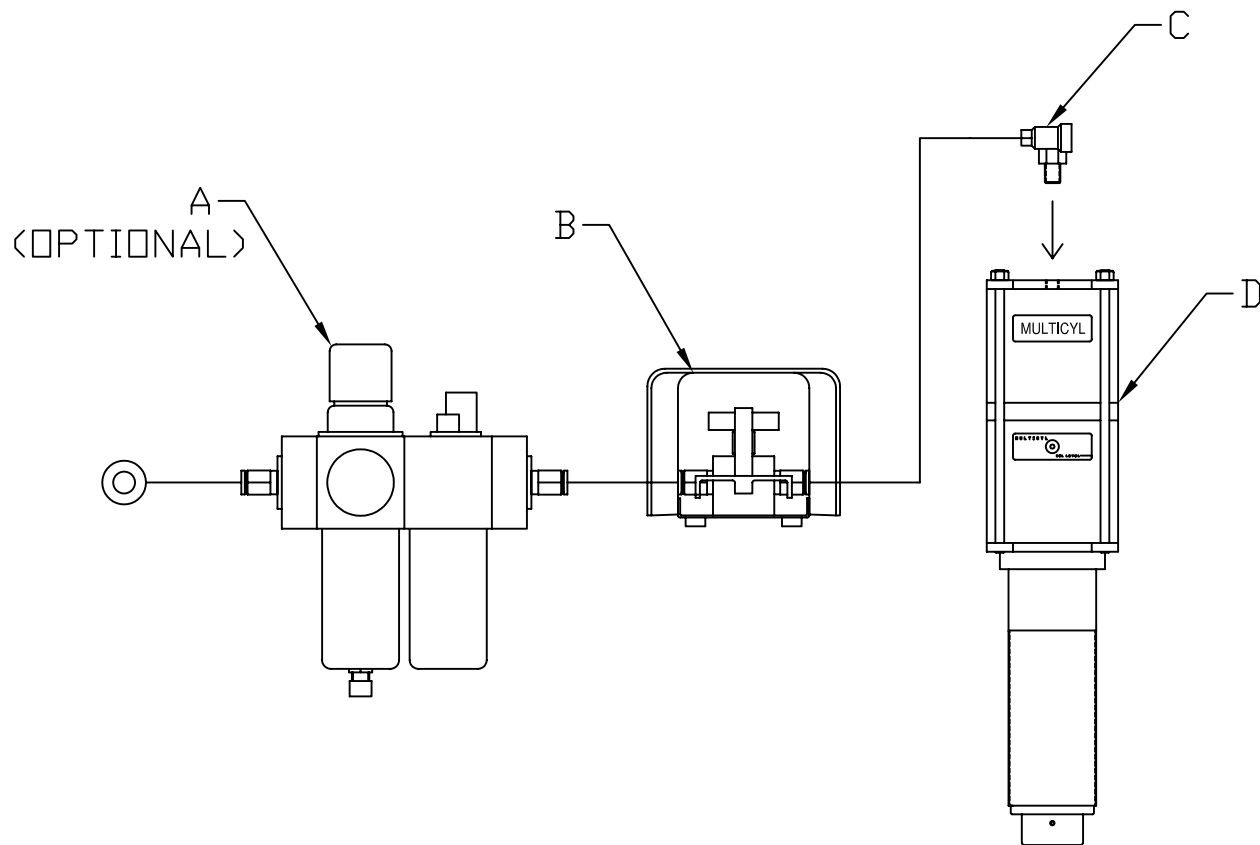

MULTICYL [®] INC.

The SPEED of AIR with the POWER of HYDRAULICS

MULTICYL [®] Inc.
 640 Hardwick Road, Unit 5
 Bolton, Ontario
 Canada L7E 5R1
 (905) 951-0670
 FAX (905) 951-0672

ACP4-P-DX CONTROL PACKAGE

NO.	PART	PART NO.
A	FILTER, REGULATOR, LUBRICATOR	FRL-500
B	PALM BUTTONS	250 F310
C	ANTI-TIE DOWN MODULE	XXXX
D	PILOT VALVE	501-3A
E	QUICK EXHAUST	SEU 1/4 DR QE4
F	MULTICYL	DM DR DX

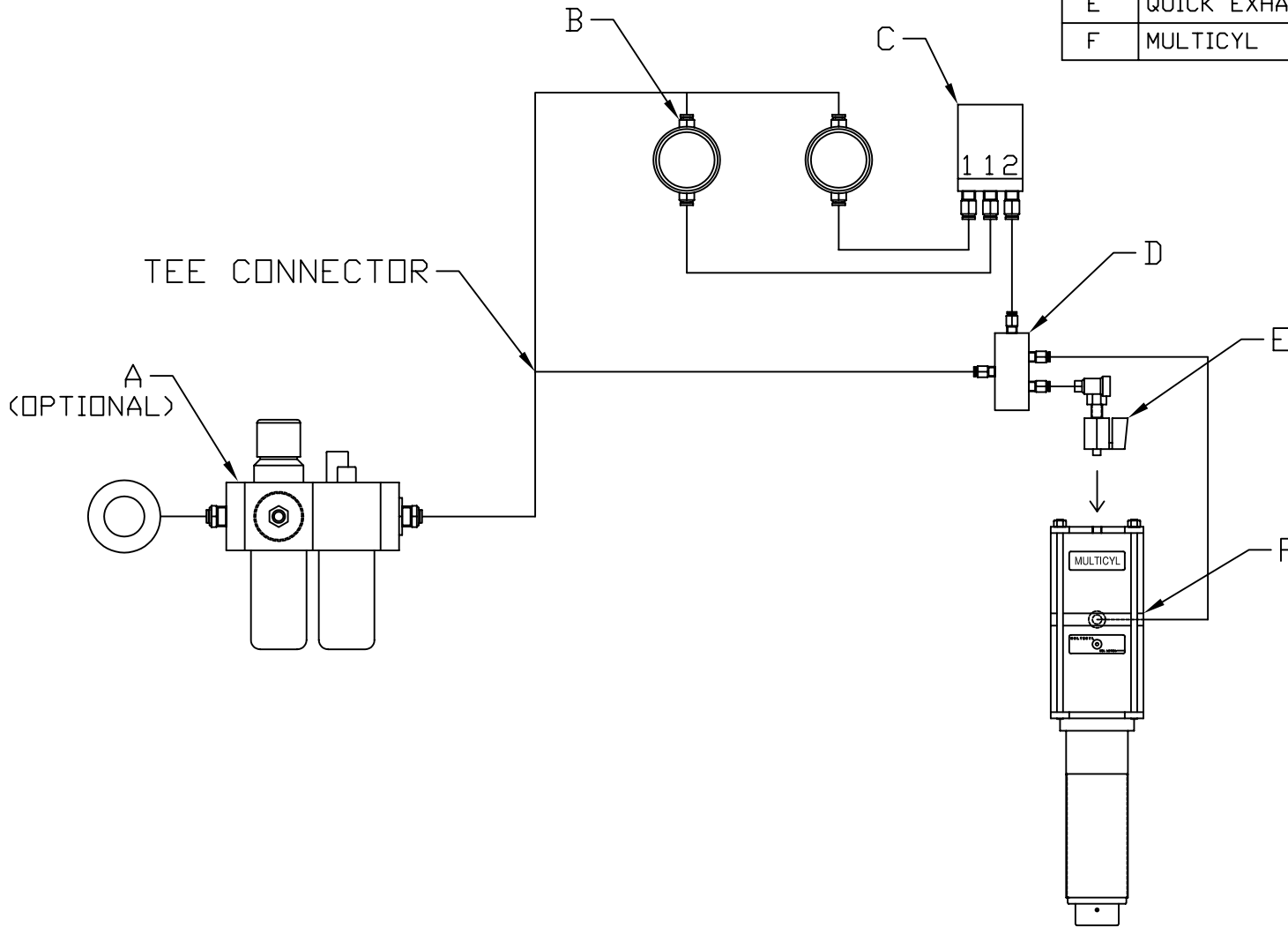

MULTICYL [®] Inc.
 640 Hardwick Road, Unit 5
 Bolton, Ontario
 Canada L7E 5R1
 (905) 951-0670
 FAX (905) 951-0672