

XL 25-5-9	XL 20-16-7	XL 15-16-16	XL 5-16-48	SPECS	
12-1/2	10	7-1/2	2-1/2	Tonnage (Nominal)	
5/8"	2"	2	1-1/2"	Overall Stroke	
9/32"	7/32"	1/2	1-1/2"	Power Stroke	
23"	26"	26"	26"	A Dimension	
12-3/4"	13"	13"	13"	B Dimension	
Operating Pressure - Min: 40 PSI Max: 120 PSI Air consumption @ 100 psi is .31 cu ft/stroke					
POWER (ACTUAL) FORCE IN TONS (@ 2,000 lbs)					
				PSI	Advance Force
8.6	7	5.2	1.7	80	660 lbf
10.8	8.8	6.5	2.2	100	750 lbf
13	10	7.8	2.7	120	825 lbf

Choosing the Right Multicyl:

The two most important factors when determining which cylinder is right for an application are **stroke** and **tonnage**. The power stroke also must be at least long enough to match the requirements of the work including the material thickness and the spring preload in the tooling. The cylinder must have a tonnage output which is at least equivalent to the tonnage that is required to complete the work. Therefore add 25% safety allowance to power stroke and tonnage for variations in air pressure, tool and material conditions.

Tonnage Calculations:

Round holes: $S \times 3.141 \times D \times T$ Shearing: $S \times \text{Shear Length} \times T$

Stripping: $\text{Shear Length} \times T \times 3500$ (force in pounds)

$S = \text{tensile strength of material}$ $D = \text{diameter}$ $T = \text{thickness}$

For example punching a .375" hole through .060" stainless steel would require a cylinder with at least 3.54 tons

$(40 \times 3.141 \times .375 \times .060) + 25\%$ and a power stroke of at least .075".

Design Tips

A **balanced load distributed within the tool** will eliminate off-center conditions to ensure trouble free operation of a Multicyl System.

Also make sure that :

- the tonnage meets the requirements of the job
- the tooling does not have a strong pre-load which inhibits the stroke
ie : die stripper / lifter springs should not be too heavy - see user guide
- die set or tooling is not attached directly to the ram.
- the tooling is well guided with a balanced load distribution
- the cyl has been cycled several times to free entrapped air
- the air control package is connected properly
- the air flow is not restricted
- the air pressure is correct
- for horizontal operation the oil filler screw is up to allow oil to transfer from reservoir into high pressure chamber

Note : the use of a Filter, Regulator, and Lubricator is mandatory to ensure uniform performance. This is the best preventative maintenance and will increase the life of the cylinder.

MINIMUM CENTER DISTANCES BETWEEN CYLINDERS
A) WHERE VERTICAL ADJUSTMENT IS STILL POSSIBLE
B) MOUNTED WHERE VERTICAL ADJUSTMENT IS NOT POSSIBLE

- Class 2A thread, 75 mm, 1.5 mm, allows fast and simple setup and adjustment → no nuts or bolts required.
- 1 1/8" Minimum clearance between tool and mounting plate.
- 3/8" NPT Air Vent for evacuating the air chamber. May be used to recycle lubricator oil.
- Uses a three-way valve and quick exhaust.

TEMPLATE **XL SERIES** SINGLE ACTING

What is Multicyl?

Multicyl pressure intensifiers are air over oil cylinders which can provide up to 12 ½ tons of power with a variety of stroke lengths. Multiple cylinders may be used with a well guided die set achieving up to 100 tons of combined force. Using Multicyl products is a safe, simple and cost effective way to accomplish practically any punching application.

The patented two stage action of Multicyl is designed maximize punching capacity while using the minimum energy possible.

The Patented Self-Adjusting Stroke of Multicyl:

The patented 'Flow By' principle allows Multicyl to self-adjust it's two stage stroke action to begin the power stroke when the resistance encountered exceeds the advance force. The stroke length will bottom out at the end of the overall stroke or wherever the power stroke is needed. Because of this self-adjusting feature our cylinders do not require a precise set-up height. An internal end stop acts as a depth control at the end of the stroke. Depth stops will also reduce the amount of air consumption if the overall stroke is reduced. The height of the cylinder can be adjusted to account for variations in tool height. For a **safer operating environment** the cylinder height can be adjusted to eliminate any nip points. For operations where open height cannot be reduced (eg. if the front loading of parts requires a larger open height) we offer a **two hand anti-tie down safety air control package**.

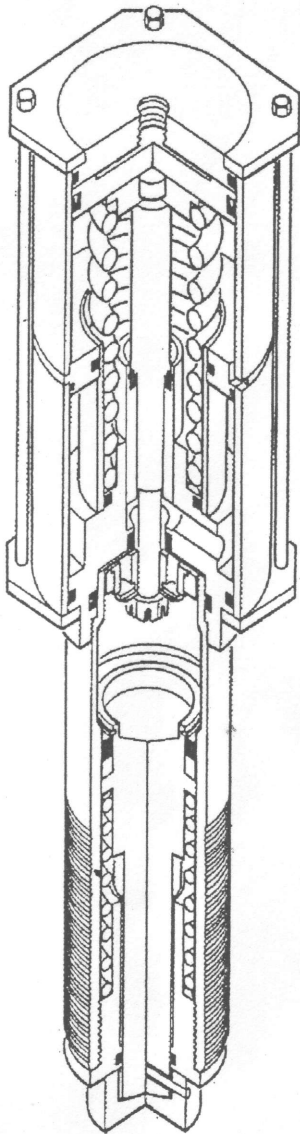

Tooling:

Note: when using a spring returned die-set, excessive spring resistance may cause premature power stroke, shortening the overall stroke. Light die lifter springs should be based on the upper die shoe weight. See example 'A' which shows too much stripper spring pre-load.

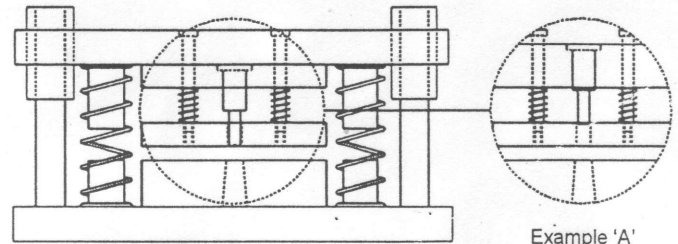

Do not attach tooling directly to the ram.

Multicyl can be used with your existing tooling or we can supply a new system for your requirements. Interchangeable punch and notch tooling from such companies as Unittool, Pierce-All and Unipunch are useable with Multicyl cylinders. The **hardened striker cap** and ram contain a spherical radius which isolates the cylinder from potential tool misalignment during the cycle. The striker cap may be removed and replaced with an **AD10 punch holder** which is available in 1/2" and 1" bore diameters.. Tool weight for stamp holders etc should not exceed 5 lbs.

The Multicyl air/oil action is self-bleeding. Entrapped air is ejected from the oil system to the air pocket above the oil reservoir.

Air Controls and Operating Pressure

Multicyls run on regular shop air with **minimum and maximum operating pressures** of 40 and 120 PSI. Air pressure input is directly proportionate to tonnage output; ie. if the incoming air pressure is reduced by 20% then tonnage output of the cylinder will also be reduced by 20%. **Multicyl air controls**, which are used to operate the system, are inexpensive and simple to use. Our standard three way foot or palm control is all that is needed and can be installed in a matter of minutes using quick connect fittings.

Care should be taken to use safe, rigid **cages** to house your Multicyl system. Inadequate cage design is not only dangerous but may cause the cage to deflect resulting in loss of power stroke. Standard cages, which can be purchased in a variety of designs and sizes, are engineered to withstand the extreme forces produced.

Use Hyspin AWS 32 non-detergent, hydraulic 150 SSU oil or equivalent. The self contained oil system eliminates the need for a separate reservoir and controls. Check oil level every year.

Multicyl units may be successfully used in the horizontal position. Upside down cylinders may be quoted by request. **Verify That the Specifications Match Your Application and Allow An Additional 25% for Variations in Air Pressure, Material and Tool Sharpness.**

MULTICYL INC.

640 Hardwick Road Unit 5, Bolton, Ontario Canada, L7E 5R1
 Tel: (905) 951-0670 Fax: (905) 951-0672 U.S. Toll Free 1-800-388-6359
 Check out our WEBSITE: [Http://www.Multicyl.com](http://www.Multicyl.com)

STANDARD MOUNTING PLATES

Fasten to Underside of Cross Beams (if possible)

For optimum support, mounting plates should be mounted on the underside of load bearing beams.

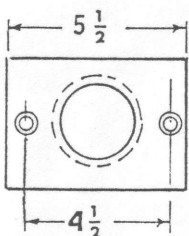

5/16" SHCS Counterbore
 MPX 12 - 1" Thick

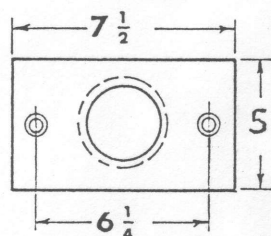

3/8" SHCS Counterbore
 MPX 18 - 1 1/4" Thick